

Optimizing Field Performance of Axial Flow Rotary Combine With Single Rotor and Snap Roll Header for Maize Harvesting

Rupinder Chandel¹ & Surinder Singh Thakur¹

¹ Department of Farm Machinery and Power Engineering, Punjab Agricultural University, Ludhiana, Punjab, India

Correspondence: Jean Dominique Gumirakiza, Department of Farm Machinery and Power Engineering, Punjab Agricultural University, Ludhiana, Punjab 141004, India. E-mail: rupinder26@gmail.com

Received: December 29, 2021

Accepted: January 29, 2022

Online Published: February 15, 2022

doi:10.5539/jas.v14n3p211

URL: <https://doi.org/10.5539/jas.v14n3p211>

Abstract

To study the effect of operational factors on combine performance, a maize combine with snap roll header was tested at feed rates levels of 69.94 Mg h⁻¹, 85.48 Mg h⁻¹, 124.33 Mg h⁻¹ and moisture content levels of 24.45%, 26.03%, 28.90% respectively. Pre harvest losses increased from 1 to 4% as the maize crop were sun dried from a grain moisture level of 28.90% to 24.45% because the ear shank became weak with decrease in moisture content. The shelling efficiency varied from 96.81% to 98.13%, cleaning efficiency varied from 95.20% to 95.80%, minimum grain damage obtained was 2.1% and minimum total loss obtained was 9.96%. The optimum values of feed rate and moisture content (w.b.) were 85.48 Mg h⁻¹ (forward speed of 1.10 km h⁻¹) and 26.03%, respectively. The corresponding data obtained for shelling efficiency, cleaning efficiency, grain damage and total loss by combine were 98.13%, 95.80%, 2.10% and 10.23%, respectively. The energy involved in maize harvesting for maize dehusker cum sheller and maize combine with snap roll header were 2152.26 and 2633.25 MJ ha⁻¹, respectively. The Solar energy is crucial for gaining optimum moisture for maize harvesting and reducing losses. Maize with low global warming potential is a viable energy crop and leftover corn stover is also a viable alternative to fossil fuels which can be used for bioethanol, silage production and also as domestic fuel in rural, hilly areas. However optimum harvesting stage is crucial to minimize energy involved during maize harvesting, grain storage and alternative uses.

Keywords: maize combine, snap roll, feed rate, shelling efficiency

1. Introduction

Maize is cultivated on nearly 178 million ha globally in about 160 countries and contributes approximately 50% (1,170 million metric tonnes (MT)) to the global grain production. In India, maize constitutes about 9% of the total volume of cereals produced and is the third most important food grain after rice and wheat. Advance estimates for total production in India stands at 9.3 million MT in trade year 2015, growing at almost 6% in the past 5 years. Policies around price correction and initiatives to improve quality can be key drivers of corn exports from India in the coming years. Mechanized harvesting and postharvest management can also provide additional yield benefits (Anonymous, 2016a). Maize is the predominant raw material (together with sugar cane) for the production of bioethanol, the most common and widespread biofuel, and at the same time the predominant raw material for biogas production, with the highest yields in Europe. A maize grain harvester consists of maize head, conveying, threshing, separation, cleaning units and a grain tank. This same maize grain harvester can not only simplify the harvesting procedure, improve production efficiency, but also reduce grain loss. Maize harvesting is one of the most important field operations of maize production. Due to the accelerated development in the maize industry, mechanized maize harvesting is widely accepted and used by farmers in the world. According to the harvesting methods, maize harvesters could be classified into two types, one is maize-for-grain harvesters which include pickers and grain harvesters, while the other one is whole plant harvesters which include forage harvesters and combined grain-stover harvesters (Yang et al., 2016). At present, maize harvesting in the United States, Germany, Ukraine, Russia and other western countries apply direct threshing because of the planting pattern of one crop a year and low grain content during harvest period (Hou, 2006; Ji et al., 2006; Zhu & Chen, 2010; Yan et al., 2007). Maize is considered to be a promising option for diversifying agriculture in upland area of India. India stands fifth in terms of production accounting for 2% of the total world maize production.

Presently, it ranks as the third most important grain crop in India after wheat and paddy. The area and production of maize in India during 2012 and 2013 were 8.67 million ha and 22.26 million tonnes, respectively (Anonymous, 2016a). The mechanization of sowing and harvesting operation play a key role in increasing land under maize crop. The remaining corn stover can be used for production of bioethanol fuel using rakes, rectangular and round baler (Sokhansanj & Turhollow, 2002), corn stover collector attachment with combine (Singh et al., 2015), manual collection method or using harvester loader machines. A study revealed that maximum higher heating value that was observed by corn stover and switchgrass was 21.51 and 21.53 MJ kg⁻¹ at 270 °C and a 120-min residence time and showed consistent proximate, ultimate, and energy properties after torrefaction,. The van Krevelen diagram drawn for corn stover and switchgrass torrefied at 270 °C indicated that H/C and O/C values are closer to coals like Illinois Basis and Powder River Basin (Jaya Shankar, 2015).

The purpose of mechanized maize harvesting is to replace manual labour to harvest maize from fields on time with minimum time loss while maintaining high quality. The harvesting method and equipment depend upon planting pattern, agronomy and climate conditions. The entire harvesting operation may be divided into gathering, snapping, husking, cutting, threshing, separation and cleaning. Reducing human drudgery and energy, increasing productivity, improving timeliness of agricultural operations and reducing peak labour demands are among the most advantages of mechanized maize harvesting. Factors affecting harvester efficiency and yield losses include combine adjustments, field space, kernel moisture levels and lodging. The harvesting operation is also considered critical, if delayed huge grain loss is resulted (Bector & Singh, 1999).

Harvesting and threshing of grain crops are two major farm operations requiring considerable energy (Baruah & Panesar, 2005). For most varieties, the losses increases rapidly as the grain moisture dropped below 25%. Ear drop losses were summed up to 85 to 95% of all losses before or during the harvesting operation. The factors affecting losses are maize variety, cylinder speed, concave clearance, type of roll. Straight-fluted rolls are more aggressive than spiral-lugged rolls. Stripper plates located above the rolls prevent maize ears from directly contacting the rolls. They can be divided into quadrangular, five ribs and six-rowed etc. according to their cross-sectional shape. The maize head of straight-fluted snapping rolls is reliable with high efficient, small losses but leads to a high mixture of stalks and husks in harvested grain (Brass, 1970). The test results showed that the concave clearance at the front place should be about 10 mm less than the average diameter of maize ears, and that it should be equal to the core diameter at the rear place (Petkevičius et al., 2008). The key feature of the longitudinal axial flow threshing device is that the maize ears are fed axially into the threshing cylinder, and the maize ears are moving in axial and tangential direction along the cylinder. It performs the threshing and separation functions and the time of threshing and separating is longer, as well as the device has lower threshing losses and grain damage. Damage in the axial device was half of that in the tangential threshing roller (Wacker, 1990). Test results shows that the complementary angle of friction which is the angle between grain and helix lamina should be larger than the helix angle of the feeding section, and the friction angle between grain and leading lathing should be larger than the helix angle of threshing and separation section (Yang & Yan, 2008). The high demand for energy worldwide and fossil fuel reserves depletion have generated increasing interest in renewable biofuel sources (Lynd et al., 2005). The use of bioethanol produced from lignocellulosic material can reduce our dependence on fossil fuels (Balat, 2011). The solid residues after LHW pretreatment of corn stover is suitable to be used as substrate for ethanol production, and the fed-batch S-SSF is one effective process for obtaining higher ethanol concentration and ethanol yield. The optimum feeding process in fed-batch S-SSF of the solid residues was that 6.1% of semi-weighted solid residues at pre-hydrolysis time of 6 h were added into the system (Li et al., 2014). Maize crop cultivation is energy efficient and it can generate energy benefits (Konieczna et al., 2021). Moisture plays an important role during maize harvesting on seed quality and harvest losses. Below 18% shattering losses will drastically increase beyond permissible limits. On the other end, corn typically has a soft pericarp at 28% moisture content and beyond. Harvesting and threshing at maize grain moisture content equal to or greater than 28% will lead to cracks and breaks in the pericarp which is not desirable by maize seed growers. Generally, around 21-22% the pericarp is much more durable and can withstand impacts better and it is easier to thresh as moisture content lowers. From a harvest loss view, the 28% moisture content value will allow harvesting sooner, less chance for stalk lodging and ears dropping on the ground. The maximum total combine losses with header ear losses as largest portion are reported in the severely lodged corn (Paulsen et al., 2014). Harvesting corn when grain moisture levels are high can result in excessive drying costs, kernel damage and harvest loss from improper threshing. The gradual increase of mechanical damage to seeds, as moisture content increased at harvest, has contributed to the reduction of seed physiological potential and to the increased occurrence of fungi during storage (Ferreira et al., 2013). Allowing corn to stay in the field too long can result in excess harvest loss from stalk lodging, ear drop or kernel shattering. Pre harvest ear losses and machine gathering losses increase as the season advances. The stalks become dry and brittle and

tend to lodge as a result of adverse weather conditions and the ears break off easier. High forward speeds and poor centering of the snapping unit on the row increase ear losses, especially when the stalks are lodged. The most important plant properties influencing mechanical damage are kernel detachment force, kernel strength, initial and final kernel thickness (kernel deformation), and cob strength. Low kernel damage is associated with low detachment force, high kernel strength, low kernel deformation, low cob strength. By changing plant characteristics, such as reducing detachment force and increasing kernel strength, it should be possible to reduce kernel damage during combining. Field losses are influenced by the type of harvester, machine adjustments, forward speed, date of harvesting, moisture content, varietal differences, amount of lodging and other factors. An optimal harvest depends not only on the condition of the crop but also on the proper maintenance and adjustment of harvest and grain handling and drying equipment.

Maize harvesting in India is done by either manual picking of cobs or threshing using conventional thresher or maize dehusker cum sheller or by maize combines. In the manual harvesting method, the crop is first pre dried to a moisture content of about 20-25%. This is done through the pre drying of maize in the field. Maize is left inside the field as such, due to action of heat from the sun which is responsible for drying maize to a moisture content of 20% from 35%. After pre drying, only ears are pulled from the stalk of the plant without the involvement of tool. The average duration of manual harvesting varies from 120 to 200 man-hours (15-25 man-days) per hectare. Shelling the ears, that is, removal of the husks covering the ears may be done by hand or by a machine at the time of harvest. If this is done by hand, it requires about 130 man-hours (about 16 man-days) per hectare. The conventional thresher is used to separate the grains from the cobs or both dehusking and threshing can be done at the same time using maize dehusker cum sheller. The output of such machine is generally around 2500 kg h⁻¹ for sheller and 2000-2500 kg h⁻¹ for dehusker cum sheller. The threshing performance is good with these threshers but they involve more labour cost and time. To reduce labour cost and time of operation farmers are also using self-propelled combine harvester with snap roll header for maize harvesting nowadays. It is a single machine which does all the harvesting operation simultaneously, *i.e.*, gathering of maize ears, dehusking, threshing and cleaning. This combine harvester uses a header arrangement in front of the machine which does the operation of separating the ears from the plant and also it gathers the ears and conveys it to the threshing cylinder. Threshing cylinder is a rotating drum with a concave around it and due to the shearing and rubbing action husk is removed and cobs are shelled. The separated grains are cleaned before sending them to the grain tank, this is done through the cleaning mechanism, which uses chaffer and cleaning sieves to separate trash from the grains. The clean grain goes to the grain tank and the trash is discharged at the back of the combine, clean grains in the tank are loaded into a trailer through an auger mechanism. Use of the combines has increased in the past due to increase in production through hybrid varieties and mechanization in India. However various parameters like, forward speed, feed rate, moisture content of crop affect the performance of combine harvesters along with quality of harvested maize grains needs to be studied which plays a major role in its storage and germination. Thus considering all these points present study was conducted to optimize the performance of maize combine harvester (picker sheller) with snap roll header in field for harvesting of maize crop to find the optimum operational and crop parameters. The study was also done to find out drying behavior and costs of harvested maize grain and to compare economics of combine with snap roll header with traditional method (manual picking and threshing with maize dehusker cum sheller) in Indian conditions.

2. Materials and Methods

2.1 Experimental Site

Maize was planted at the research farm of the Farm Machinery and Power Engineering Department during 2013, 2014 and 2015 planting season. The climate of the area is semi-arid, with an average rainfall of 700 mm (75-80% of which occurs from July to September), minimum temperature of 0-4 °C in January, maximum temperature of 41-45 °C in June, and relative humidity of 67-83% throughout the year. The soil (0-15 cm) of the experimental field was sandy loam in texture.

2.2 Crop and Combine Harvester Information

Combine header and combine was checked for all repair and maintenance. Before operating the combine harvester in the field total grain yield was recorded in the field by collecting samples from different locations. The pre-harvest losses were negligible. Maize varieties PMH-2, Pioneer-1844, DKC-9108 were taken for the present study. Maize crop was sown at recommended spacing of 0.60 m by 0.20 m in experimental plots. The mean stalk height, girth, weight and grain yield varied between 2.00-2.29 m, 49.23-60.30 mm, 9.58-11.52 Mg ha⁻¹ and 6.29-7.02 Mg ha⁻¹ [at 21% m.c. (w.b.)], respectively for the different experimental plots. The mean cob outer diameter with husk varied between 42.74-44.68 mm. A six row maize combine with snap roll header (Figure 1)

was at the experimental plots with maize crop during 2013, 2014, 2015 planting season to study the effect of operational factors such as feed rate and moisture content on shelling efficiency, cleaning efficiency, grain damage and various losses. The combine had twelve snap rolls (device for gathering a maize and picking up cobs), *i.e.*, two for each row and clearance between two consecutive snap rolls was kept as 10 mm (Figure 2). After being snapped maize cobs were conveyed towards auger by chain conveyor mechanism (Figure 3). The clearance between upper strips was 28 mm. Combine had self-propelled engine of 78.33 kW and rasp bar type threshing cylinder (Figure 4) with diameter and width as 606 mm and 1250 mm, respectively. The overall width of combine was 3800 mm (Figure 5) and effective width of cut was 3000 mm. Maize header effective width was calculated by measuring the average distance between the centre lines of adjacent picking units multiplied by the number of units. Provision made for adjusting the header width, the maximum and minimum dimensions were stated according to (IS 8122 (Part 1): 1994), which was reaffirmed in 1999. The snapping rolls were straight fluted tolls having tapered, spiral ribbed points to facilitate stalk entry. Straight fluted rolls pull the stalks down between two stripper plates and the ears are snapped off when they contact the plates. Six straw walkers were provided in the combine with a length of 3770 mm and width of 234 mm each. Its sieve system had two sieves, upper sieve had area of 2.3 m² and lower sieve had area of 1.3 m² (Table 1).



Figure 1. A view of six row snap roll header



Figure 2. Snap roll



Figure 3. Chain conveyor



Figure 4. Maize combine threshing cylinder

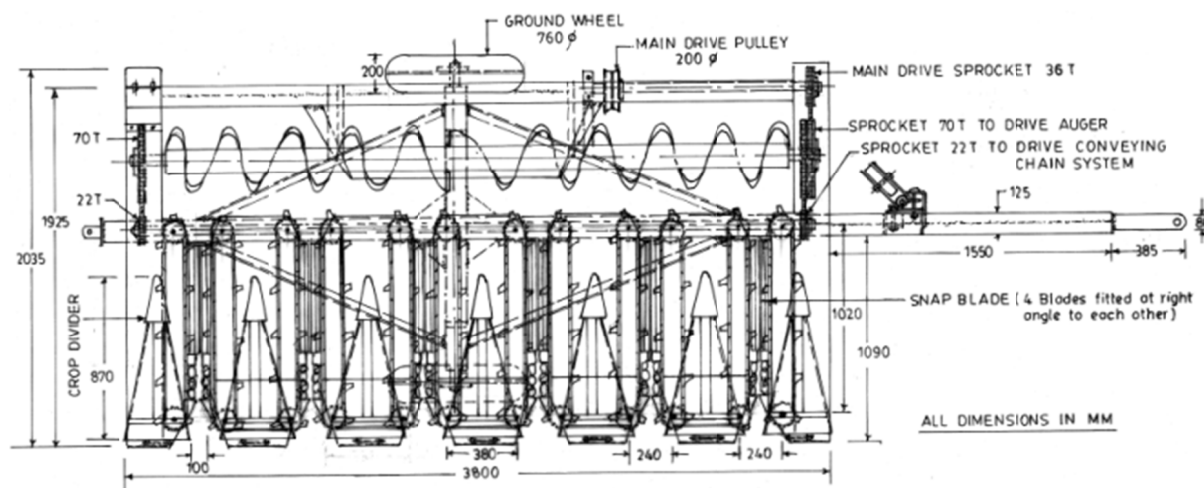
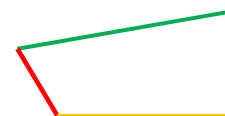

Figure 5. Top view of maize header with snap roll

Table 1. Brief specifications of maize combine with snap roll header

Different systems of combine	Specifications
Model	Ashok Leyland
Engine Power	78.33 kW at 2200 rpm
No. of Cylinder	6
Air Cleaner	Combination of dry and wet type
Cooling System	Water Cooled
Clutch	
Type of Clutch	Single, Heavy Duty Dry Clutch
Diameter (mm)	310
Transmission	
No. of Gears	3 Forward, 1 Reverse
Forward Gear speeds (km h ⁻¹)	L H
1 st Gear	2.4
2 nd Gear	4.8
3 rd Gear	8.20
Reverse Gear	4.8
Cutter bar mechanism	
Width of header, m	3.60
Spacing between crop divider, m	0.60
No. of rows	6

Total No. of snap rolls	12
No. of blades on snap roll	4 (fitted at 90° to each other)
Snap cutting blade - total length, mm	550
Spiral rib in front of snap roll, mm	220
Total snap roll length, mm	770
Clearance between two rolls, mm	10
Clearance between upper strips, mm	28
Lug dimensions, mm	
Front length (taper, green)	700
Rear length (horizontal, yellow)	60
Front width (taper, red)	20
Rear width (horizontal, black),	40
Vertical height of lug	30
Horizontal spacing between two lugs on chain (one's rear, one's front), mm	200
Chain length, mm	2280
Chain length upto snap roll portion, mm	950
Effective cutting width, mm	3000
Auger Window, mm	1295 × 330
Threshing Mechanism	
Threshing cylinder type	Rasp bar type
Diameter, mm	606
Width, mm	1250
Speed, rpm	540-1200 rpm
Speed Adjustments	By means of mechanical variator
Concave	
Grate size (mm)	35 × 16
Clearance (mm)	Front-24 mm, Rear-17 mm
Adjustment	Mechanical
Cleaning Sieves Area (m ²)	
Upper Sieve	2.47
Lower Sieve	1.70
Grain Tank (m ³)	2.60
Fuel Tank capacity (ltr)	365
No. of Batteries	2
Capacity and rating of each	12V, 88 Ah
Tyre	Size Ply Rating
Front	18.4/15 × 30 12pr/14pr
Rear	9.00 × 16 16 pr
Main Dimensions (In Working, mm)	
Length	8370
Width	3800
Height	3800
Ground Clearance	340
Main Dimensions(In Transport,mm)	
Length	12280
Width	3045
Height	3800
Weight, tonne	8.580 Approx.



Line diagram for lug

Each snapping blade had four blades fitted at right angle to each other (Figure 6). Stop watch was used to measure forward speed of the combine. Measuring tape was used to measure the dimensions of the field. A cloth was used to collect the samples from different locations of the field for different losses. Weighing balance was used to measure the weight of threshed grain, unthreshed grain and straw of maize crop. Oven was also used to measure moisture content of the maize grain.

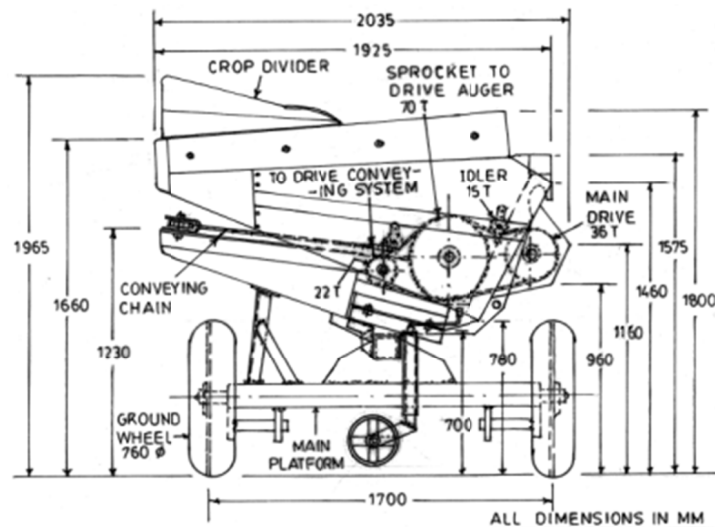

Figure 6. Side view of maizeheader with snap roll

2.3 Equipment Used for Various Parameters

The weighing of grains and biomass was done using an electronic weighing balance. For measuring plot dimension a measuring tape was used. The unthreshed cobs and shattered ears from the field were handpicked.

For measuring the header losses, cobs were collected from the field using an area of $3 \times 3 \text{ m}^2$ at different locations in the field and then grains were collected from the cobs and were weighed to calculate the losses.

2.4 Moisture Content Determination

Standard air-oven method used in United States was considered to determine maize grain moisture content prior to field experiments. Air-Oven Reference Method for Moisture in Corn and Beans is the difference in weight after drying an unground sample of grain for 72 hours at $103 \pm 1 \text{ }^\circ\text{C}$. The moisture of corn grains was tested using the method used by Lee (2012).

Moisture content of grain is usually determined on wet basis (w.b.) using the formula provided in Equation (1):

$$MC_{wb} = \frac{W_i - W_f}{W_i} \quad (1)$$

where, MC_{wb} = Moisture content wet basis (%); W_i = Initial weight, g; W_f = Final weight, g (Anonymous, 2016b).

2.5 Feed Rate Determination

In each of the experimental plot, biomass was collected from different spots in the field in rows for standard lengths (to be used for calculating combine harvester forward speed) and it was weighed on an electronic balance without cobs. Then feed rate (Mega gramperha, Mg ha^{-1}) for material other than grain was calculated using the formula provided in Equation (2).

$$\text{Feed rate, (MOG)} = \frac{aw}{t} \quad (2)$$

where, a is constant-3.6; w is weight of the biomass measured in standard row length, kg; t is time of combine travel for standard row length, second.

2.6 Forward Speed

At different moisture contents, maize crop was harvested. The operational speed of machine was calculated as:

$$v = \frac{3.6 \times S}{T} \quad (3)$$

where, v is operational speed, km h^{-1} ; S is distance covered, m; T is time taken in seconds.

2.7 Estimation of Field Capacity and Various Losses Measurement

The effective field capacity was determined by measuring all the time elements involved while harvesting. The total time was categorized into productive and non-productive time. The productive time is the actual time used

for harvesting the grains while the non-productive time consisted of the turning time, repair and adjustment time and other time losses. The area covered divided by the total time gave the effective field capacity. The grain losses were determined based on the grain yield recorded during harvesting operation. Shattering loss refers to the ears and grains fallen on the ground during harvesting. Rack and shoe losses were measured from the material discharged by the machine. Samples were collected from 3.0 m by 3.6 m size plots from the field at different locations after the combine harvester operation. Total machine loss refers to the summation of header, rack and shoe losses. The quality of maize grain was determined in terms of broken grains percentage and cleaning efficiency, which was determined by taking three samples of grain from the grain tank of the combine harvester, each weighing 200 g. These samples were taken at successive time intervals depending on the size of the field. Foreign matter were manually sorted and weighed to calculate percentage (%) broken grains and cleaning efficiency. The effective field capacity of combine was calculated using the expression provided by Kepner et al. (1978):

$$C = \frac{SW}{10} \times \frac{E_f}{10} \quad (4)$$

where, C is effective field capacity, ha h⁻¹; S is speed of travel, km h⁻¹; W is rated width of implement, m; E_f is Field efficiency, in percent.

$$E_f = \frac{100 \cdot T_o}{T_e + T_h + T_a} \quad (5)$$

where, T_o is theoretical time per hectare (per acre); T_e is effective operating time = T_o × 100/K; K is percent of implement width actually utilized; T_h is time lost per acre due to interruptions that are not proportional to area. At least part of T_h usually tends to be proportional to T_e; T_a is time lost per acre due to interruptions that tend to be proportional to area.

2.8 Estimation of Fuel Consumption

Before starting the test, the engine's fuel tank was completely filled. The quantity of fuel required to fill the tank after harvesting the test field was measured using 1 litre graduated cylinder. Thus, the fuel consumed during the test was determined.

$$F = \frac{L}{A} \quad (6)$$

where, F is the fuel consumption in l ha⁻¹; A is the area harvested in ha; L is the quantity of fuel required to fill the tank after harvesting the test field in l.

2.9 Calculations of Various Losses and Efficiencies in Combine Operation

2.9.1 Pre-harvest Losses

Pre-harvest losses are those caused by shattering and lodging, and loss of dry matter due to birds, wildlife, weather and other natural causes. Pre-harvest losses are important but are not related to machine performance. Large pre-harvest losses indicate a genetic weakness in some varieties and a need for further breeding work to develop plants less susceptible to lodging and with stronger bonds between the ears and the stalks. Pre-harvest losses increase as the season progresses. This can go much higher in adverse crop years or when harvest is delayed. The combine header width multiplied by the distance stepped off represents 1/100 acre. To measure pre-harvest losses, required distance was stepped off in standing corn. The length of corn rows for this 1/100 acre varies with row width and number of rows covered by corn head (Table 2). For header width of 3.6 m it was calculated as 11 m. All the loose and lodged ears in these rows were counted and gathered to calculate the pre-harvest losses. The pre-harvest losses were calculated as follows:

$$\text{Pre-harvest losses, (\%)} = \frac{\text{Weight of grains from naturally fallen cobs (kg)}}{\text{Total grain yield (kg)}} \times 100\% \quad (7)$$

2.9.2 Header and separation loss (L_{s+h})

The loose kernels and cobs on ground behind the combine were collected in 1/100 acre area. For header width of 3.6 m it was calculated as 11 m. This represented the total header plus separation loss (L_{s+h}).

Table 2. Row length in feet per 1/100 acre

Row width	One row	Two rows	Three rows	Four rows	Six rows	Eight rows	Twelve rows
20 inches	262	131	87.3	65.5	43.6	32.7	
28 inches	187	93.5	61.3	46.7	31.1	23.3	
30 inches	174	87	58	43.6	29	21.8	14.5
36 inches	145	72.5	48.3	36.2			
38 inches	138	69	46	34.5			
40 inches	131	65.5	43.6	32.7			
42 inches	124	62	41.3	31			

$$\text{Header and separation losses, (\%)} = \frac{\text{Weight of grains from rear of combine (kg)}}{\text{Total grain yield (kg)}} \times 100\% \quad (8)$$

2.9.3 Header Ear Loss (L_h)

For measuring header losses data for fallen cobs and kernels in front of machine where the separator had not yet passed. The combine was backed off by distance equal to length of combine. Loose kernels, broken and whole cobs were gathered from this front area ($w \times l$). These were gathered to calculate the header losses. The header ear losses were calculated as:

$$\text{Header ear loss, (\%)} = \frac{\text{Weight of grains [loose and from fallen cobs (kg)]}}{\text{Total grain yield (kg)}} \times 100\% \quad (9)$$

2.9.4 Separation Kernel Loss (L_s)

These were obtained by subtracting header rear loss from header and separation loss which could be expressed mathematically as:

$$L_s = L_{s+h} - L_h \quad (10)$$

where, L_s is Separation loss, %; L_h is Header rear losses, %; L_{s+h} is header and separation losses, %.

2.9.5 Cylinder Loss (L_c) and Shelling Efficiency (η_{sh})

For measuring cylinder loss and shelling efficiency kernels still attached to the threshed cobs were collected from 1/100 acre area and weighed. The small kernels at the butt and tip end of cobs were not taken. Shelling efficiency is defined as the mass of the kernels actually shelled to the total mass of kernels on the ear before shelling. The expression used for calculating shelling efficiency was given by Al-Jalil (1978) as:

$$\text{Shelling efficiency, (\%)} = \left(1 - \frac{L}{W+L}\right) \times 100\% \quad (11)$$

where, L is shelling loss (weight of unshelled kernels attached to the cob), kg; W is mass of shelled kernels, kg.

Samples weighing 200 g for cleaning and broken kernels were collected from the grain tank of the combine after the operation. These samples were then cleaned to get the trash content, broken grains and clean grains for calculating grain damage (G_d) and cleaning efficiency (η_c).

$$\text{Grain damage, (\%)} = \frac{\text{Weight of broken grains (kg)}}{\text{Weight of original sample (kg)}} \times 100\% \quad (12)$$

$$\text{Cleaning efficiency, (\%)} = \frac{\text{Weight of clean grains (kg)}}{\text{Weight of original sample (kg)}} \times 100\% \quad (13)$$

2.10 Data Analysis

All data varying from shelling efficiency, cleaning efficiency and losses obtained from the experiment were analyzed using factorial experiment in completely randomized design with CPCS1 software ($p < 0.05$).

2.11 Energetics and Economics

A complete inventory of all inputs (machine, fuel, human labor), after which the energy value of each input was determined through published conversion coefficients derived only from peer-reviewed literature, expressed in MJ ha⁻¹. Fuel consumption and time required per hectare was measured for both machines in each harvesting season, with average values extrapolated for energy calculation. The energy required for drying maize crop at different stages of moisture content with maize combine and that of whole maize harvesting process was calculated for both machines. The economics of maize crop harvesting was also calculated for both machines.

3. Results

Table 3 presents details of the area of maize harvested on the field during 2013, 2014 and 2015 planting season. The pre-harvest losses varied between 1 and 4% [(62.9-251.6 kg/ha for maize moisture content reduced to 21% (w.b.)] at different locations. As the maize crops were sun dried in field to reduce moisture content, pre-harvest losses also increased. In maize combine various adjustments were done to minimize field losses and increase field efficiency. In the threshing unit, the concave clearance at the front was kept at 24.0 mm and at the rear was kept at 17 mm. The threshing cylinder speed varied between 600 and 700 rpm as the engine speed varied between 1600 and 1800 rpm during field experiments. The gear used was mostly 1st medium or 1st low. The speed of snap roll cutter varied between 464 and 500 rpm. The combine was operated at different forward speeds at the experimental plots. The forward speeds were maintained at 0.90 km h⁻¹, 1.10 km h⁻¹ and 1.60 km h⁻¹, respectively to vary the feed rate. The cutting height varied between 400-450 mm during different field experiments.

Table 3. Detail of maize area harvested with snap roll header type maize combines at farmer's fields during 2013, 2014 and 2015

Year	Maize area harvested, ha	Maize varieties	Locations
2013	80	PMH-2, Pioneer-1844, DKC-9108	Jalandhar
2014	86	PMH-2, Pioneer-1844, DKC -9108	Jalandhar, Kapurthala, Ludhiana
2015	78	PMH-2, Pioneer-1844, DKC -9108	Jalandhar, Kapurthala, Ludhiana

The field capacity of maize combine varied between 0.20 and 0.50 ha h⁻¹ and the fuel consumption values varied between 7 and 10 l h⁻¹ during field experiments. Grain samples were taken from three different plots and were kept in an oven for recording the moisture content. In general, maize crop moisture was asymptotical over time and reached moisture content values of 24.45%, 26.03%, 28.90% (w.b.) for the three stages of harvest. The combine was evaluated on maize varieties PMH-2, Pioneer-1844 and DKC-9108 at feed rates (MOG) of 69.94 Mg h⁻¹, 85.48 Mg h⁻¹ and 124.33 Mg h⁻¹, respectively. After operating the combine in the experimental plots (Figures 7, 8 and 9), the shelled and unshelled grains were collected from the rear of combine. After that, shelled and unshelled kernels were weighed on the electronic balance and the various losses obtained were measured using different equation expressions given in the Materials and Methods section. The measured data were analyzed graphically and statistically. The statistical analysis package called CPCS1 software was used.



Figure 7. A view of maize combine during field operation (with corn stover collector attachment at rear)



Figure 8. A view of snap roll type header



Figure 9. A view of axial flow rotary combine with single rotor and snap roll maize header during field operation at Departmental Research Farm, PAU, Ludhiana and at farmer's field

Grain breakage initially decreased with decrease in moisture content and further increased with increase in feed rate as grain moisture content decreased. Grain damage further increased as feed rate decreased from 124 Mg h^{-1} to 69.94 Mg h^{-1} when grain moisture content increased from 24.45 to 28.90%. The first shelling and cleaning efficiency first increased as moisture content of grain were at 26.04% but as feed rate increased in feed rate both shelling and cleaning efficiency decreased (Figure 10). Though, moisture content of the grain reduced but due to increase in feed rate cleaning and shelling efficiency both reduced. However header losses increased considerably from 9.96 to 15.34% with increase in feed rate and decrease in moisture content (Figure 11) and the effect was significant at 5% level of significance. Mean separation losses initially decreased with decrease in moisture content from 28.90 to 26.03% but as moisture was further decreased to 24.45% mean separation losses increased. Overall increase in separation losses may be attributed to decrease in moisture content and corresponding increase in feed rate (MOG). The separation losses were highest at moisture level of 28.90% reason being that at higher moisture separation efficiency reduces due to presence of sticky material. Cylinder losses decreased with decrease in grain moisture content from 28.90 to 24.45% and further decreased as grain moisture content increased from 24.45 to 26.03%. Header losses increased with increase in feed rate as moisture content decreases but then decreased with increase in moisture content as feed rate further decreased. The highest header losses was recorded at moisture content of 24.45%. Total losses initially increased with increase in feed rate and later decreased as feed rate decreases. The various predictive equations as contained in Table 6 were obtained from graph plots.

Table 4. Effect of feed rate and moisture content on Meanheader, cylinder, separation and total losses

Sr. No.	Feed rate (Mg h ⁻¹)	Mean header losses (L _h , %)	Mean cylinder losses (L _c , %)	Mean separation losses (L _s , %)	Mean total losses (%)	Mean moisture content (w.b.%)
1	85.48	6.18	1.87	2.18	10.23	26.03
2	124.33	10.00	2.61	2.73	15.34	24.45
3	69.94	2.79	3.19	3.98	9.96	28.90
F-ratio	-	1501.93	274.28	1750.93	220.41	-
LSD _{0.05}	-	0.322448	0.138607	0.0762167	0.707379	-
C.V.	-	2.55	2.71	1.29	2.99	-

Table 5. Effect of feed rate and moisture content on Grain damage, Shelling efficiency and Cleaning efficiency

Sr. No.	Mean feed rate (Mg h ⁻¹)	Mean grain damage (G _d , %)	Mean shelling efficiency (η _{sh} , %)	Mean cleaning efficiency (η _c , %)	Mean moisture content (w.b.%)
1	85.48	2.10	98.13	95.80	26.03
2	124.33	2.30	97.39	94.60	24.45
3	69.94	2.80	96.81	93.70	28.90
F-ratio	-	96.03	6.97	15.49	-
LSD _{0.05}	-	0.126381	0.862294	0.926252	-
C.V.	-	2.64	0.44	0.49	-

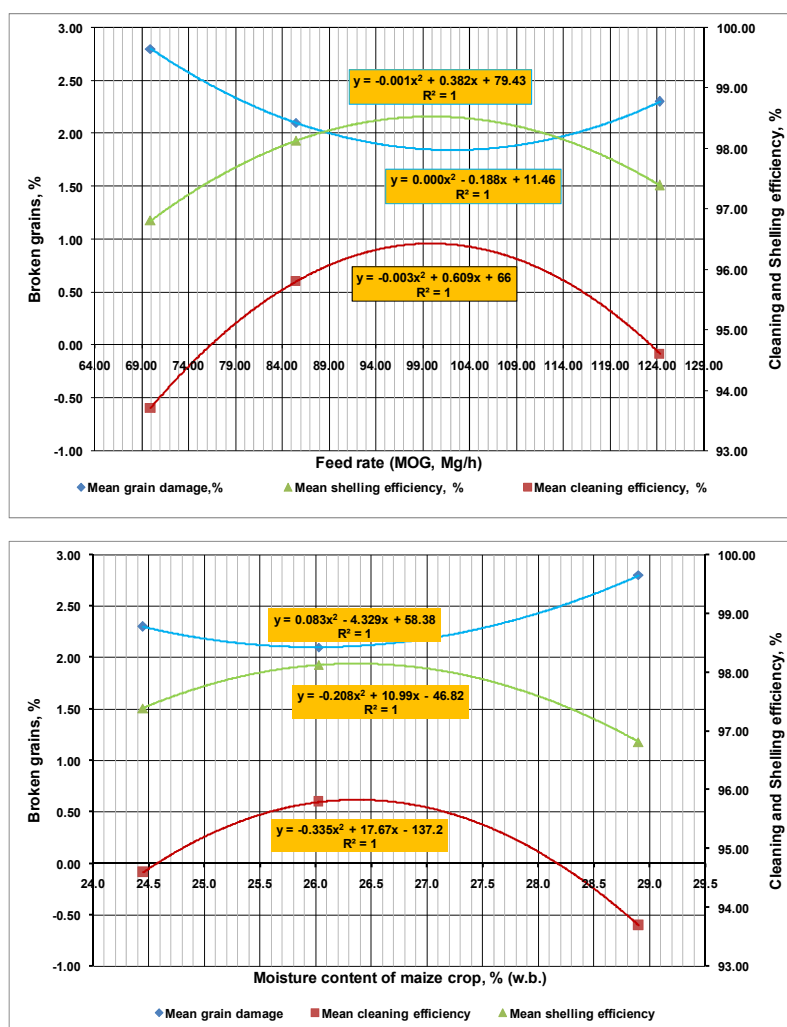

Figure 10. Effect of feed rate (MOG) and moisture content of maize crop on mean grain damage, cleaning and shelling efficiency

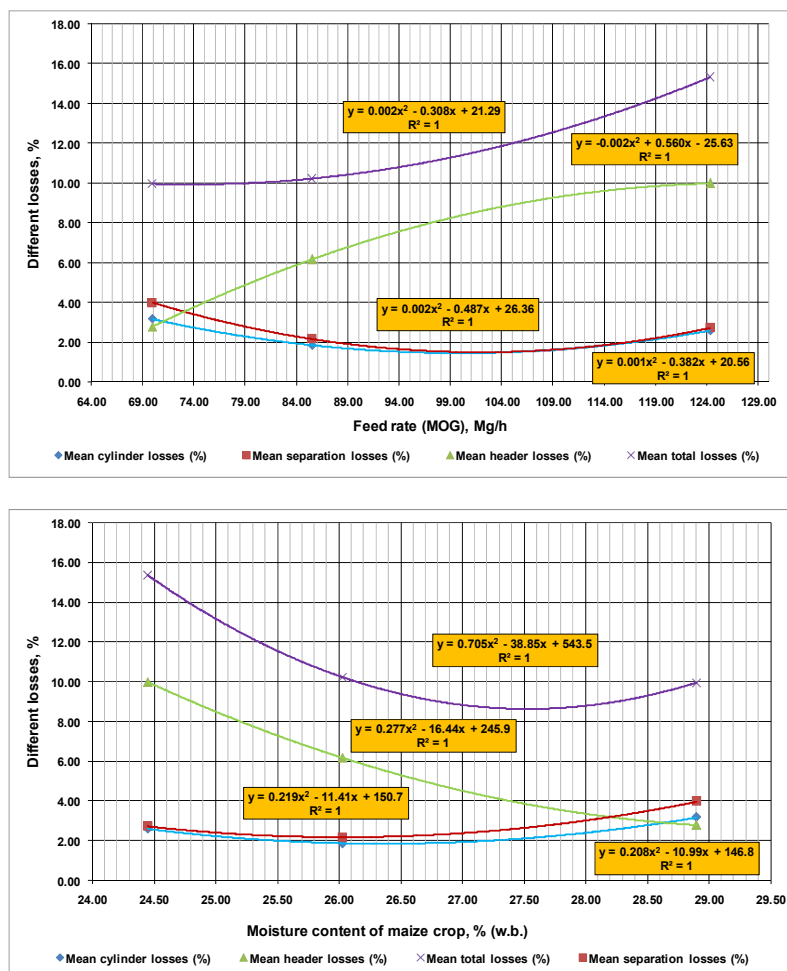

Figure 11. Effect of feed rate (MOG) and moisture content on different losses

Table 6. Various combine performance prediction equations as a function of feed rate and moisture content

S. No.	Performance parameters	f [feed rate, F_r ($Mg\ h^{-1}$)]	F [grain moisture content, M_c (% w.b.)]
1.	Shelling Efficiency	$-0.001F_r^2 + 0.382F_r + 79.43$	$-0.208M_c^2 + 10.99M_c - 46.82$
2.	Cleaning Efficiency	$-0.003F_r^2 + 0.609F_r + 66.00$	$-0.335M_c^2 + 17.67M_c - 137.20$
3.	Grain damage	$0.000F_r^2 - 0.188F_r + 11.46$	$0.083M_c^2 - 4.329M_c + 58.38$
4.	Header losses	$-0.002F_r^2 + 0.560F_r - 25.63$	$0.277M_c^2 - 16.44M_c + 245.90$
5.	Cylinder losses	$0.001F_r^2 - 0.382F_r + 20.56$	$0.208M_c^2 - 10.99M_c + 146.80$
6.	Separation losses	$0.002F_r^2 - 0.487F_r + 26.36$	$0.219M_c^2 - 11.41M_c + 150.70$
7.	Total losses	$0.002F_r^2 - 0.308F_r + 21.29$	$0.705M_c^2 - 38.85M_c + 543.50$

These prediction equations can be used for evaluating the performance of maize combine at different moisture contents and feed rates.

4. Economic Analysis

The economic analysis of maize combine with snap roll header was done using the traditional method. Using the conventional method, 8 to 10 persons pick cobs from one acre area between 8 and 10 h. The cobs are transported to the threshing unit where they would be threshed using maize dehusker cum sheller (Figure 12). This machine comprises of an axial spike tooth type threshing cylinder with a suitable concave and a thrower mechanism to eject empty stalk and husk. Grains fall on the cleaning sieves for cleaning. The thresher can thresh the dehusked maize cobs having moisture content in the range of 12-24% successfully. This machine saves one extra operation

of removing cover from maize cobs. The field capacity and fuel consumption varied between 0.5 and 1.5 acre h^{-1} and 3.0-5.0 $l h^{-1}$ during field experiments conducted at farmer's fields.



Figure 12. A view of Maize dehusker cum sheller during operation at Departmental research farm and at farmer's fields

The thresher can be operated with a 35 hp tractor. The engine speed varied between 600 and 1800 rpm depending upon crop condition and tractor model. Labour requirement for thresher operation varied from 3 to 5 persons. Its capacity varies between 2.0 and 2.5 $Mg h^{-1}$. The farmers are mostly using maize dehusker cum sheller for maize threshing owing to its lower cost than maize combine. At present, there are around 1800 maize shellers in Punjab (2012-2013). Although maize crop is mostly threshed using maize dehusker cum sheller but nowadays farmers are also using combines for maize harvesting due to weather instability. At present, there are around 50 maize combines in the state. The total cost of harvesting one hectare area with maize combine with snap roll header is about Rs. 4958.10 whereas for conventional method is about Rs. 11365.96 (Table 7).

Table 7. Economics maize combine with snap roll header with conventional method

Particulars	CT ¹	MCH ²
Cost of machine, Rs. unit ⁻¹ (Cost in USD per unit)	120,000.00 (\$1880.88)	1,900,000.00 (\$29780.56)
Manual cob picking cost, Rs. ha ⁻¹	7,812.50	0.00
Cobs transportation cost, Rs. ha ⁻¹	500.00	0.00
Operational cost*, (Fixed and variable), Rs. ha ⁻¹	3,053.46	4,958.10
Grand total cost, Rs. ha ⁻¹ (USD** per ha)	11,365.96 (\$ 178.15)	4,958.10 (\$ 77.71)
Total man, h ha ⁻¹	288.00	47.00
Saving in cost as compared with conventional method, %	-	56.38%
Saving in time as compared with conventional method, %	-	83.68%

Note. Diesel cost* at Rs. 52 l^{-1} , (1 USD** = 63.80 Indian Rupee), ¹: Conventional treatment-manual cob picking and threshing with Maize dehusker cum sheller; ²: MCH-Maize combine harvester with snap roll header.

4.1 Cost Calculations for Natural Sun Drying of Maize Grains Harvested With Combine Harvester at Different Moisture Contents to Safe Storage Moisture Content

The safe storage moisture content for maize grain varies between 10 and 12% (w.b.). The harvested crop can be spread on hard ground, on roofs, on purpose-built platforms or on trays. As the crop is exposed to the sun, it will fairly dry quickly depending on the humidity of the ambient air. The produce should be stirred frequently to ensure even drying. The disadvantage of this method is that the crop has to be taken in or covered every evening or before rain. The labour requirements may be reduced considerably by placing the harvest on a plastic or tarpaulin sheet for easy handling (used in present study) or on a platform/tray covered by transparent plastic. The detail of meteorological data and labour cost for sun drying of maize grains between moisture content 10 and 12% (w.b.) in present study was calculated (Table 8).

Table 8. Meteorological data detail and cost calculations for sun drying of maize grains

Moisture content (w.b.) (%)	Drying time (8-h daily) (No. of days)	Meteorological data for the month of October at Punjab Agricultural University (<i>Kharif</i> season)				Equivalent drop in 1000 grain weight corresponding to 3% decrease in grain m.c. (w.b.) (g)	Labour requirement for stirring of maize grains (man-h ha ⁻¹)	Labour cost involved in natural grain drying (Rs. ha ⁻¹)	Percent increase in drying cost as compared with 24.45% moisture content (%)
		Avg. effective sunshine hrs. (Min.-Max.) (h)	Avg. temp (Min.-Max.) (°C)	Avg. wind speed (Min.-Max.) (Km h ⁻¹)	Mean relative humidity [Min.(E)-Max. (M)] (%)				
28.90	7	7.6 (0-11.2)	25.20 (13.5-34.2)	2.6 (0.7-10.3)	68 (28-96)	8.9 g	42	1312.50 (\$ 20.57)	28.57
26.03	6	7.6 (0-11.2)	25.20 (13.5-34.2)	2.6 (0.7-10.3)	68 (28-96)	8.9 g	36	1125.00 (\$ 17.64)	16.67
24.45	5	7.6 (0-11.2)	25.20 (13.5-34.2)	2.6 (0.7-10.3)	68 (28-96)	8.9 g	30	937.50 (\$ 14.69)	-

Note. Labour cost at Rs. 31.25 (0.49 USD) per h.

Height above mean sea level: 355 meters; Hours of observation: Morning (M) 0730 hours IST; Evening (E) 1430 hours IST.

The increase in cost of drying at 28.90% and 26.03% moisture contents were 28.57% and 16.67% higher when compared with 24.45% moisture content. However, the higher cost of drying in 26.03% moisture content was compensated as contained in Tables 4 and 5 by lesser grain damage (2.10%), lower cylinder losses (1.87%), lower separation losses (2.18%) and higher shelling efficiency (98.13%) and cleaning efficiency (95.80%) during mechanical harvesting. The added advantage of higher moisture is in bioethanol production and silage production. In general, high-moisture silages have higher concentrations of soluble N and NH₃-N than drier silages because of the overall more robust fermentation in the former. Higher than normal levels of soluble N and NH₃-N in wet legume silages are usually a result of proteolytic activity from clostridia. Similarly moisture content between 15-40% was considered good for bioethanol production from maize, switchgrass, wheat, fiber sorghum and sugarcane residues (Kung et al., 2018; Hattori & Morita, 2010).

4.2 Energy Calculation for Axial Flow Rotary Combine With Single Rotor and Snap Roll Maize Header and Maize Dehusker Cum Sheller

The energy calculations were done based on energy equivalents for machinery, fuel and human labour taken for mean of various reviews (Table 9).

Table 9. Energy input and output calculations for maize combine harvester with snap roll header (MCH) and maize dehusker cum sheller (CT)

Particulars	Unit	Energy Equivalent (MJ unit ⁻¹)	Reference	Quantity by area (unit ha ⁻¹)		Total energy (MJ ha ⁻¹)		Percentage (%) of total energy	
				CT ¹	MCH ²	CT	MCH	CT	MCH
Machinery	Hour	409.87	Pishgar-Komleh et al. (2013)	2.50	2.86	1024.68	1172.23	47.61	44.52
Diesel	Litre	56.31	Barut et al. (2011); kumar et al.(2013); Shahin et al. (2008); Yadav et al. (2013)	10.00	24.31	563.10	1368.90	26.16	51.99
Human labour	Person-h	1.96	Barut et al. (2011); Kumar et al.(2013); Shahin et al. (2008); Yadav et al. (2013)	288.00	47.00	564.48	92.12	26.23	3.50
Total						2152.26	2633.25	100.00	100.00

Note. ¹: Conventional treatment-manual cob picking and threshing with Maize dehusker cum sheller; ²: MCH-Maize combine harvester with snap roll header.

The total energy requirements were 2152.26 and 2633.25 MJ ha⁻¹ for maize harvesting with conventional method (CT) and maize combine with snap roll header (MCH). It is clear from Table 2 that the energy required in maize combine with snap roll header was 22.35% approximately higher than conventional method. Again the higher energy requirement was compensated by lower human labour requirement and higher field capacity in case of maize combine harvester with snap roll header. Both factors make it feasible to use the maize combine harvester

for commercial harvesting which fetches more profit to owners. If the optimized parameters for the harvester were used the owners can get more harvesting rates and more working hours.

5. Discussion

One hundred percent of the acreages in large corn producing nations (United States and Argentina) sow and harvest maize mechanically (Figure 13). China has increased its mechanical harvesting from 16% in 2010 to 33% in 2013. With increase in mechanical harvesting, large maize producing nations have experienced increase in yields. In India, the mechanical sowing and harvesting penetration has only been 5 to 7%. Farm losses (due to poor harvesting practice or lack of timely labour) can potentially be controlled through mechanization. Increase in thrust on promotion and adoption of mechanical harvesting could potentially assist in improving productivity and control farm losses. Overall mechanization of maize crop harvesting can reduce maize cultivation costs especially labour costs and provide a good employment opportunity for rural youth to run these machines on custom hiring basis and thus can raise their economic status. Also rural youth can open workshops after taking technical training on these machines for repair and maintenance of these machines which is another employment aspect for them. The usage of maize grain after harvesting as desired by purchaser is also a key driver for determining optimum moisture stage.

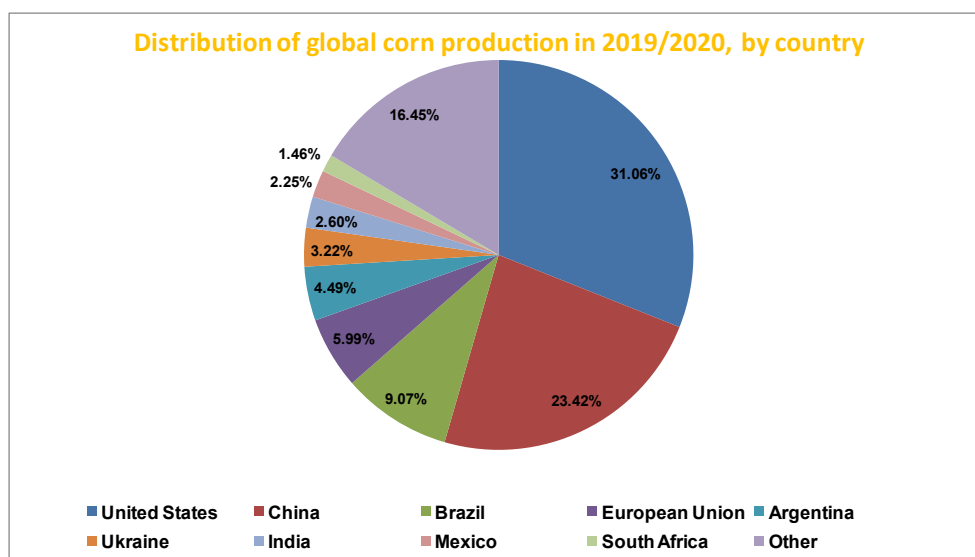

Figure 13. Distribution of global corn production

Source: <https://www.statista.com/statistics/254294/distribution-of-global-corn-production-by-country-2012>

Farmer prefer harvesting at higher moisture content as purchasers prefer this moisture as they sell it for beer so that farmer could get it a rate of 950 to 1000 Rs. qtl.⁻¹ and if harvested after drying as desired by seed producers then they get it a rate of 1000 to 1300 Rs. qtl.⁻¹. But harvesting at optimum conditions can fetch them a good profit. Overall use of mechanical harvester can be beneficial in recovering more grain yield and increasing area under maize cultivation. But from seed production and storage point of view the optimum conditions for maize combine harvester and maize crop play a crucial role which was worked out in present study. The drying time and costs were also calculated after mechanized harvesting of maize crop with mechanical harvester with snap roll header. Keeping in view the weather conditions and moisture level of maize crop, present research gives a decision criteria to help maize growers for selection of optimized parameters for mechanical harvesting of maize crop with snap roll header with minimum field losses. Alongwith this Biofuel compared with fossil fuels is considered to be more effective. For example with oil, coal and natural gas to produce 1 MJ of electricity; non-renewable energy consumption is projected to be between 1.7 and 4.2 MJ whereas biomass values range from 0.1 to 0.4 MJ. In the case of thermal energy, prices are 1.1 and 1.5 for fossil fuels and only 0.01-0.15 for biomass. Although the energy is considered to be CO₂ neutral, in fact there is actually a burden on greenhouse gas emissions due to the process of cultivation and harvesting. However, this charge does not exceed the total emissions of fossil fuels which results in being up to 90% reduced (Ingenito et al., 2012). The biomass produced can be used heating as raw material for thermochemical processes such as pyrolysis and gasification for the

production of methanol, biogas and pyrolytic oils and for combustion or cogeneration for coal, electricity and for biochemical processes (for example, fermentation) for the production of ethanol or methane (Ness & Moghtaderi, 2007; Voloshin et al., 2016). The remaining stover after combine harvesting of maize could be used for bioethanol and or as a fuel in rural areas, cold regions like leh ladakh and where there is shortage of other energy producing fuels. Analysis suggests that to produce sufficient stover to support large biorefineries along with sustainable agriculture, erosion control and soil moisture concerns, policy related to percent area under corn stover removal need to be specified and farmers should shift to universal no-till production of corn (Graham et al., 2007). The rapid development of technology and the constant increase in the number of the world's population combined with the pollution of the environment lead to the need to find new energy resources more friendly and efficient. Energy crops can provide a large amount of energy by exploiting unused agricultural pieces of land or degraded land without burdening environments compared to fossil fuels. Maize with low global warming potential is one of the best representatives of cereal energy crops and presents great prospects in food grain, bioethanol sector, bio-CNG, bio coal, biomass pellets/briquettes, and also in silage industry. The selection of optimum harvesting parameters helps in lesser energy demands during grain storage, lesser energy in corn stover collection, bio fuel production as well as in silage industry.



Figure 14. Collection of maize corn stover using cob collector attachment behind combine and baler system

A view of maize corn stover collection with cob collector attachment and using baler system is shown in Figure 14. Similarly a view of rectangular baler and various transportation systems for crop residue is shown in Figure 15. The corn stover yields between 5-6.25 t ha⁻¹.



Figure 15. Collection of crop residue round bales by using hydraulic trolleys and rectangular bales by manual loading

6. Conclusion

In this study, the maximum shelling efficiency recorded was 98.13% at feed rate of 85.48 Mg h⁻¹ and moisture content of 26.03%. The shelling efficiency initially increased with decrease in moisture content of maize crop and then increased with increase in moisture content. Mean header losses increased upto 15.34% at feed rate of 124.33 Mg h⁻¹ and grain moisture content of 24.45%, however, drying costs were lowered at this moisture content. The cleaning efficiency was observed to be maximum at 95.80% as the grain damage was found to be minimum at 2.10% for feed rate of 85.48 Mg h⁻¹ and moisture content of 26.03%. This was the minimum damage observed in the experiment. The mean totalloss was minimum at 9.96% for feed rate of 69.94 Mg h⁻¹ and grain moisture content of 28.90%. This was the minimum loss observed in the experiment. The optimum values of feed rate and grain moisture content (w.b.) are 85.48 Mg h⁻¹ (forward speed of 1.10 km h⁻¹) and 26.03%, respectively. At this moisture the corn stover baling is also beneficial as it can be utilized efficiently in bioethanol production and silage production. The silage making also require a higher moisture content for maize crop. However, the energy and cost involved in sun drying was higher at moisture levels of 28.90% and 26.03% when compared with 24.45%. The cost of drying were 28.57% and 16.67% higher when compared with 24.45% moisture content. The saving in cost and time with maize combine with snap roll header in comparison with conventional method were 56.38% and 89.92%, respectively.

Various factors were studied together to provide information for combine owners, farmers and researchers a methodology and solution for getting more profits from mechanical harvesting of maize crop at optimum parameters.

References

- Al-Jalil, H. F. (1978). *Design and performance of low damage corn shelling machines* (pp. 9-10, PhD dissertation, Iowa State University, USA).
- Anonymous. (2016a). Retrieved July 21, 2016, from <http://www.indiastat.com>
- Anonymous. (2016b). Retrieved October 25, 2016, from http://www.knowledgebank.irri.org/index.php?option=com_zoo&view=item &layout=item &Itemid=735

- Balat, M. (2011). Production of bioethanol from lignocellulosic materials via the biochemical pathway: A review. *Energy Convers and Manage*, *52*, 858-875. <https://doi.org/10.1016/j.enconman.2010.08.013>
- Baruah, D. C., & Panesar, B. S. (2005). Energy Requirement Model for a Combine Harvester. Part I: Development of Component Models. *Biosystems Eng.*, *90*, 9-25. <https://doi.org/10.1016/j.biosystemseng.2004.08.017>
- Barut, Z. B., Ertekin, C., & Karaagac, H. A. (2011). Tillage effects on energy use for cornsilage in Mediterranean Coastal of Turkey. *Energy*, *36*, 5466-5475. <https://doi.org/10.1016/j.energy.2011.07.035>
- Bector, V., & Singh, S. (1999). Timeliness loss factor for different operations of major crops in Punjab. *Journal of Inst. of Engineers of India*, *79*, 32-35.
- Brass, R. W. (1970). *Development of a low damage maize shelling cylinder* (MS dissertation, Iowa State University, Iowa).
- Ferreira, V. D. F., Oliveira, J. A., Ferreira, T. F., Reis, L. V., Andrade, V. D., & Neto, J. C. (2013). Quality of maize seeds harvested and husked at high moisture levels. *J. Seed Sci.*, *35*, 1-6. <https://doi.org/10.1590/S2317-15372013000300001>
- Goss, J. R., Bainer, R., Curley, R. G., & Smeltzer, D. G. (1955). Field tests on combines in corn. *Agricultural Engineering*, *36*, 794-796.
- Graham, R. L., Nelson, R., Sheehan, J., Perlack, R. D., & Wright, L. L. (2007). Current and Potential U.S. Corn Stover Supplies. *Agronomy Journal*, *99*, 1-11. <https://doi.org/10.2134/agronj2005.0222>
- Hattori, T., & Morita, S. (2010). Energy Crops for Sustainable Bioethanol Production: Which, Where and How? *Plant Production Science*, *13*, 221-234. <https://doi.org/10.1626/pp.13.221>
- Hou, H. T. (2006). Maize harvest machinery at home and abroad. *Modern Agricultural Equipment*, *1*, 74-75.
- Ingenito, A., Andriani, R., Agresta, A., & Gamma, F. (2012). *A comparative study of combustion between biofuels and fossil fuels* (pp. 1-8). 10th International Energy Conversion Engineering Conference, July 30, 2012-August 1, 2012, American Institute of Aeronautics and Astronautics, Atlanta, Georgia. <https://doi.org/10.2514/6.2012-4054>
- Jaya Shankar, T. (2015). Comparison of chemical composition and energy property of torrefied switchgrass and corn stover. *Frontiers in Energy Research*, *3*(46), 1-11. <https://doi.org/10.3389/fenrg.2015.00046>
- Ji, J. J., Liu, H. X., Hao, J. K., & Wu, H. Y. (2006). A review of the development of maize harvest machinery at home and abroad. *Contemporary Farm Machinery*, *4*, 17-21.
- Kepner, R. A., Bainer, R., & Barger, E. L. (1978). *Principles of farm machinery* (pp. 25-28). Westport: AVI Publishing Company.
- Konieczna, A., Roman, K., Roman, M., Sliwinski, D., & Roman, M. (2021). Energy Efficiency of Maize Production Technology: Evidence from Polish Farms. *Energies*, *70*(14), 1-20. <https://doi.org/10.3390/en14010170>
- Kumar, V., Saharawat, Y. S., Gathala, M. K., Jat, A. S., Singh, S. K., Chaudhary, N., & Jat, M. L. (2013). Effect of different tillage and seeding methods on energy use efficiency and productivity of wheat in the Indo-Gangetic Plains. *Field Crop Res.*, *142*, 1-8. <https://doi.org/10.1016/j.fcr.2012.11.013>
- Kung, Jr. L., Shaver, R. D., Grant, R. J., & Schmidt, R. J. (2018). Silage review: Interpretation of chemical, microbial, and organoleptic components of silages. *Journal of Dairy Science*, *101*(5), 4020-4033. <https://doi.org/10.3168/jds.2017-13909>
- Lee, G. D. (2012). Grain Moisture Air-Oven Reference Methods in the United States. *Weights and Measures Connection*, *3*, 1-8.
- Li, X., Lu, J., Zhao, J., & Qu, Y. (2014). Characteristics of Corn Stover Pretreated with Liquid Hot Water and Fed-Batch Semi-Simultaneous Saccharification and Fermentation for Bioethanol Production. *PLoS*, *9*(4), 1-11. <https://doi.org/10.1371/journal.pone.0095455>
- Li, Y., Tao, C., Zhe, Q., Kehong, L., Xiaowei, Y., Dandan, J., Bingxin, Y., & Dongyue, Z. (2016). Development and application of mechanized maize harvesters. *Int. J. Agric. and Biol. Eng.*, *9*, 15-28.
- Lynd, L. R., Van Zyl, W. H., McBride, J. E., & Laser, M. (2005). Consolidated bioprocessing of cellulosic biomass: an update. *Curr Opin Biotechnol*, *16*, 577-583. <https://doi.org/10.1016/j.copbio.2005.08.009>

- Morrison, C. S. (1955). Attachment for combining corn. *Agricultural Engineering*, 36, 792-794.
- Ness, J., & Moghtaderi, B. (2007). Chapter 1: Biomass and Bioenergy. *Coal-Biomass Cofiring Handbook* (pp. 1-36). Cooperative Research Centre for Coal in Sustainable Development. Retrieved from https://www.researchgate.net/publication/309127353_Chapter_1_Biomass_and_Bioenergy
- Paulsen, M. R., Pinto, F. D. A. D. C., Sena, D. G. D., Zandonadi, R. S., Ruffato, S., Costa, A. G., ... Danao, M. G. C. (2014). Measurement of combine losses for corn and soybeans in Brazil. *Applied Engineering in Agriculture*, 30, 841-855.
- Petkevičius, S., Špokas, L., & Steponavičius, D. (2008). Substantiation of technological parameters of wet maize ear threshing. *Agronomy Research*, 6(SP), 271-280.
- Pickard, G. E. (1955). Laboratory studies of corn combining. *Agricultural Engineering*, 36, 792-794.
- Pishgar-Komleh, S. H., Keyhani, A., Mostofi-Sarkari, M. R., & Jafari, A. (2013). Assessment and Determination of Seed corn combine harvesting losses and energy consumption. *Elixir Agriculture*, 54, 12631-12637.
- Shahin, S., Jafari, A., Mobli, H., Rafiee, S., & Karini, M. (2008). Effect of farm size on energy ratio on wheat production: a case study from Arbadil province of Iran. *Am. Eurasian J. Agric. Environ. Sci.*, 3, 604-608.
- Singh, M., Thakur, S. S., Chandel, R., & Sharma, A. (2015). Development and Field Evaluation of Corn-Stover Collector attachment for Maize Combine Harvester. *Agricultural Engineering Today*, 39(3), 3-9.
- Sokhansanj, S., & Turhollow, A. F. (2002). Baseline cost for corn stover collection. *Applied Engineering in Agriculture*, 18(5), 525-530. <https://doi.org/10.13031/2013.10153>
- Voloshin, R. A., Rodionova, M. V., Zharmukhamedov, S. K., Nejat Veziroglu, T., & Allakhverdiev, S. I. (2016). Review: Biofuel production from plant and algal biomass. *International Journal of Hydrogen Energy*, 41(39), 17257-17273. <https://doi.org/10.1016/j.ijhydene.2016.07.084>
- Wacker, P. (1990). Factors influencing grain damage in axial and tangential threshing units. *Landtechnik*, 45, 222-224.
- Yadav, S. N., Chandra, R., Khura, T. K., & Chuhan, N. S. (2013). Energy input-output analysis and mechanization status for cultivation of rice and maize crops in Sikkim. *Agric. Eng. Int. CIGR J.*, 15, 108-116.
- Yan, H. Y., Chen, X. G., & Wu, W. F. (2007). Analysis on maize harvesters classification. *Journal of Agricultural Mechanization Research*, 10, 213-215.
- Yang, F. F., & Yan, C. L. (2008). Movement analysis of cereal in axial flow threshing roller space. *Transactions of the CSAM*, 39, 48-50.
- Yang, L., Tao, C., Zhe, Q., Kehong, L., Xiaowei, Y., Dandan, H., ... Dongxing, Z. (2016). Development and application of mechanized maize harvesters. *Int J Agric & Biol Eng*, 9, 15-28.
- Zhu, J. C., & Chen, J. H. (2010). Present situation and technical characteristics analysis of maize combine harvester in home and abroad. *Agricultural Technology and Equipment*, 4, 23-24.

Copyrights

Copyright for this article is retained by the author(s), with first publication rights granted to the journal.

This is an open-access article distributed under the terms and conditions of the Creative Commons Attribution license (<http://creativecommons.org/licenses/by/4.0/>).